



Ugelli assiali a getto piatto - Serie OV
Axial-feed vee-jet nozzles - OV Series



Caratteristiche

- Elevata forza d'impatto
- Vasta gamma di portate ed angoli di spruzzo
- La proiezione del getto ha estremità rastremate
- Privi di componenti interni evitano l'intasamento
- Disponibili con attacco rapido integrato

Features

- High impact force
- Wide range of flows and spray angles
- The jet projection has tapered ends
- No internal components, obstruction-proof
- Available with quick-clamp connection

Applicazioni

- Lavaggio e raffreddamento materiali
- Trattamento superfici
- Sistemi antincendio
- Raffreddamento serbatoi
- Lavatrici e lavastoviglie industriali
- Vasche galvaniche
- Industria siderurgica, tessile e cartaria

Applications

- Materials washing and cooling
- Surface treatments
- Fire-fighting systems
- Tanks cooling
- Industrial washing and dishwashing machines
- Chemical-industrial treatments
- Galvanic bath tanks
- Iron and steel industries, textile industries and paper factories

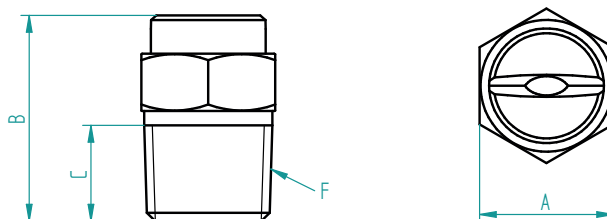
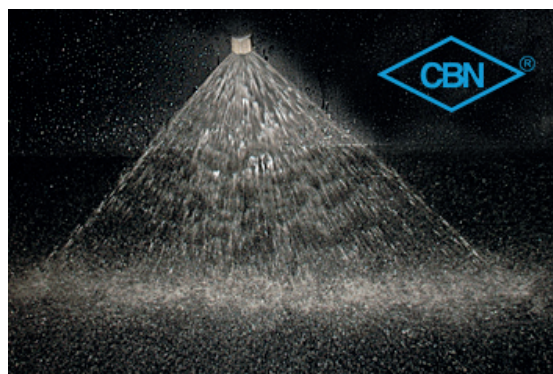

Dimensioni Dimensions	Codice Raccordo - Thread Code					
	Y31	Y32	Y33	Y34	Y35	Y36
F	1/8" BSPT	1/4" BSPT	3/8" BSPT	1/2" BSPT	3/4" BSPT	1" BSPT
A	10	14	17	22	27 (28)	36
B	16	21,5	25	30	35	40
C	7,5	10	12	14	15	17

Materiali Materials	Codice Raccordo - Thread Code					
	Y31	Y32	Y33	Y34	Y35	Y36
AISI 316 02	x	x	x	x	x	x
AISI 303 04	x	x	x	x	x	x
Ottone-Brass 06	x	x	x	x	x	x
PVC 08	-	x	x	x	x	x

	Codice Raccordo - Thread Code						CODICE PORTATA FLOW CODE	Curva di funzionamento - Operating Curve							
	1/8"	1/4"	3/8"	1/2"	3/4"	1"		Portata - Flow rate [l/min] alla pressione - at pressure [bar]							
	Y31	Y32	Y33	Y34	Y35	Y36		0,5	1	1,5	2	3	5	7	10
Angolo / Angle 25°	x						337	0,40	0,57	0,69	0,80	0,98	1,26	1,50	1,79
	x						359	0,63	0,88	1,08	1,25	1,53	1,98	2,34	2,80
	x	x					383	1,00	1,41	1,73	2,00	2,45	3,16	3,74	4,47
	x	x					394	1,25	1,77	2,17	2,50	3,06	3,95	4,68	5,6
	x	x					406	1,60	2,26	2,77	3,20	3,92	5,06	6,0	7,2
	x	x					418	2,00	2,83	3,46	4,00	4,90	6,3	7,5	8,9
	x	x					429	2,50	3,54	4,33	5,0	6,1	7,9	9,4	11,2
	x	x					453	4,00	5,7	6,9	8,0	9,8	12,6	15,0	17,9
			x				475	6,3	8,8	10,8	12,5	15,3	19,8	23,4	28,0
			x				499	10,0	14,1	17,3	20,0	24,5	31,6	37,4	44,7
				x			522	16,0	22,6	27,7	32,0	39,2	51	60	72
				x	x		545	25,0	35,4	43,3	50	61	79	94	112
					x		569	40,0	57	69	80	98,0	126	150	179
						x	591	63	88	108	125	153	198	234	280
							615	100	141	173	200	245	316	374	447



	Codice Raccordo - Thread Code						CODICE PORTATA FLOW CODE	Curva di funzionamento - Operating Curve							
	1/8"	1/4"	3/8"	1/2"	3/4"	1"		Portata - Flow rate [l/min] alla pressione - at pressure [bar]							
	Y31	Y32	Y33	Y34	Y35	Y36		0,5	1	1,5	2	3	5	7	10
Angolo / Angle 45°	x						337	0,40	0,57	0,69	0,80	0,98	1,26	1,50	1,79
	x						359	0,60	0,90	1,10	1,25	1,53	1,98	2,34	2,80
	x	x					383	1,00	1,41	1,73	2,00	2,45	3,16	3,74	4,47
	x	x					406	1,60	2,26	2,77	3,20	3,92	5,1	6,0	7,2
	x	x					418	2,00	2,83	3,46	4,00	4,90	6,3	7,5	8,9
	x	x					429	2,50	3,54	4,33	5,0	6,1	7,9	9,4	11,2
	x	x					441	3,15	4,45	5,5	6,3	7,7	10,0	11,8	14,1
	x	x					453	4,00	5,7	6,9	8,0	9,8	12,6	15,0	17,9
		x					464	5,0	7,1	8,7	10,0	12,2	15,8	18,7	22,4
		x					475	6,3	8,8	10,8	12,5	15,3	19,8	23,4	28,0
		x					488	8,0	11,3	13,9	16,0	19,6	25,3	29,9	35,8
		x	x				499	10,0	14,1	17,3	20,0	24,5	31,6	37,4	44,7
		x	x				510	12,5	17,7	21,7	25,0	30,6	39,5	46,8	56
			x				522	16,0	22,6	27,7	32,0	39,2	51	60	72
			x				534	20,0	28,3	34,6	40,0	49,0	63	75	89
				x			545	25,0	35,4	43,3	50	61	79	94	112
				x			557	31,5	44,5	55	63	77	100	118	141
				x			569	40,0	57	69	80	98	126	150	179
					x		580	50	71	87	100	122	158	187	224
					x		591	63	88	108	125	153	198	234	280
					x	604	80	113	139	160	196	253	299	359	
					x	615	100	141	173	200	245	326	374	447	

	Codice Raccordo - Thread Code						CODICE PORTATA FLOW CODE	Curva di funzionamento - Operating Curve							
	1/8"	1/4"	3/8"	1/2"	3/4"	1"		Portata - Flow rate [l/min] alla pressione - at pressure [bar]							
	Y31	Y32	Y33	Y34	Y35	Y36		0,5	1	1,5	2	3	5	7	10
Angolo / Angle 60°	x						313	0,25	0,35	0,43	0,50	0,61	0,79	0,94	1,12
	x						337	0,40	0,57	0,69	0,80	0,98	1,26	1,50	1,79
	x						348	0,50	0,71	0,87	1,00	1,22	1,58	1,87	2,24
	x						359	0,63	0,88	1,08	1,25	1,53	1,98	2,34	2,80
	x	x					372	0,80	1,13	1,39	1,60	1,96	2,53	2,99	3,58
	x	x					383	1,00	1,41	1,73	2,00	2,45	3,16	3,74	4,47
	x	x					394	1,25	1,77	2,17	2,50	3,06	3,95	4,68	5,6
	x	x					406	1,60	2,26	2,77	3,20	3,92	5,1	6,0	7,2
	x	x					418	2,00	2,83	3,46	4,00	4,90	6,3	7,5	8,9
	x	x					429	2,50	3,54	4,33	5,0	6,1	7,9	9,4	11,2
	x	x					441	3,15	4,45	5,5	6,3	7,7	10,0	11,8	14,1
	x	x					453	4,00	5,7	6,9	8,0	9,8	12,6	15,0	17,9
		x					464	5,0	7,1	8,7	10,0	12,2	15,8	18,7	22,4
		x					475	6,3	8,8	10,8	12,5	15,3	19,8	23,4	28,0
		x					488	8,0	11,3	13,9	16,0	19,6	25,3	29,9	35,8
		x	x				499	10,0	14,1	17,3	20,0	24,5	31,6	37,4	44,7
		x	x				510	12,5	17,7	21,7	25,0	30,6	39,5	46,8	56
			x				522	16,0	22,6	27,7	32,0	39,2	51	60	72
			x				534	20,0	28,3	34,6	40,0	49,0	63	75	89
				x			545	25,0	35,4	43,3	50	61	79	94	112
			x			557	31,5	44,5	55	63	77	100	118	141	
			x			569	40,0	57	69	80	98	126	150	179	
				x		580	50	71	87	100	122	158	187	224	
				x		591	63	88	108	125	153	198	234	280	
					x	604	80	113	139	160	196	253	299	359	
					x	615	100	141	173	200	245	326	374	447	

Angolo / Angle 75°	Codice Raccordo - Thread Code						CODICE PORTATA FLOW CODE	Curva di funzionamento - Operating Curve							
	1/8"	1/4"	3/8"	1/2"	3/4"	1"		Portata - Flow rate [l/min] alla pressione - at pressure [bar]							
	Y31	Y32	Y33	Y34	Y35	Y36		0,5	1	1,5	2	3	5	7	10
x							337	0,40	0,57	0,69	0,80	0,98	1,26	1,50	1,79
x							359	0,63	0,88	1,08	1,25	1,53	1,98	2,34	2,80
x	x						383	1,00	1,41	1,73	2,00	2,45	3,16	3,74	4,47
x	x						406	1,60	2,26	2,77	3,20	3,92	5,1	6,0	7,2
x	x						418	2,00	2,83	3,46	4,00	4,90	6,3	7,5	8,9
x	x						429	2,50	3,54	4,33	5,0	6,1	7,9	9,4	11,2
x	x						453	4,00	5,7	6,9	8,0	9,8	12,6	15,0	17,9
		x					475	6,3	8,8	10,8	12,5	15,3	19,8	23,4	28,0
		x					488	8,0	11,3	13,9	16,0	19,6	25,3	29,9	35,8
		x					499	10,0	14,1	17,3	20,0	24,5	31,6	37,4	44,7
			x				522	16,0	22,6	27,7	32,0	39,2	51	60	72
				x			545	25,0	35,4	43,3	50	61	79	94	112
				x			569	40,0	57	69	80	98	126	150	179
					x		591	63	88	108	125	153	198	234	280
						x	615	100	141	173	200	245	326	374	447

Angolo / Angle 90°	Codice Raccordo - Thread Code						CODICE PORTATA FLOW CODE	Curva di funzionamento - Operating Curve							
	1/8"	1/4"	3/8"	1/2"	3/4"	1"		Portata - Flow rate [l/min] alla pressione - at pressure [bar]							
	Y31	Y32	Y33	Y34	Y35	Y36		0,5	1	1,5	2	3	5	7	10
x							313	0,25	0,35	0,43	0,50	0,61	0,79	0,94	1,12
x							337	0,40	0,57	0,69	0,80	0,98	1,26	1,50	1,79
x							348	0,50	0,71	0,87	1,00	1,22	1,58	1,87	2,24
x							359	0,63	0,88	1,08	1,25	1,53	1,98	2,34	2,80
x	x						372	0,80	1,13	1,39	1,60	1,96	2,53	2,99	3,58
x	x						383	1,00	1,41	1,73	2,00	2,45	3,16	3,74	4,47
x	x						394	1,25	1,77	2,17	2,50	3,06	3,95	4,68	5,6
x	x						406	1,60	2,26	2,77	3,20	3,92	5,1	6,0	7,2
x	x						418	2,00	2,83	3,46	4,00	4,90	6,3	7,5	8,9
x	x						429	2,50	3,54	4,33	5,0	6,1	7,9	9,4	11,2
x	x						441	3,15	4,45	5,5	6,3	7,7	10,0	11,8	14,1
x	x						453	4,00	5,7	6,9	8,0	9,8	12,6	15,0	17,9
		x					464	5,0	7,1	8,7	10,0	12,2	15,8	18,7	22,4
		x					475	6,3	8,8	10,8	12,5	15,3	19,8	23,4	28,0
		x					488	8,0	11,3	13,9	16,0	19,6	25,3	29,9	35,8
		x					499	10,0	14,1	17,3	20,0	24,5	31,6	37,4	44,7
		x	x				510	12,5	17,7	21,7	25,0	30,6	39,5	46,8	56
			x				522	16,0	22,6	27,7	32,0	39,2	51	60	72
			x				534	20,0	28,3	34,6	40,0	49,0	63	75	89
				x			545	25,0	35,4	43,3	50	61	79	94	112
				x			557	31,5	44,5	55	63	77	100	118	141
				x			569	40,0	57	69	80	98	126	150	179
					x		580	50	71	87	100	122	158	187	224
						x	591	63	88	108	125	153	198	234	280
							604	80	113	139	160	196	253	299	359
							615	100	141	173	200	245	326	374	447

Angolo / Angle 120°	Codice Raccordo - Thread Code						CODICE PORTATA FLOW CODE	Curva di funzionamento - Operating Curve							
	1/8"	1/4"	3/8"	1/2"	3/4"	1"		Portata - Flow rate [l/min] alla pressione - at pressure [bar]							
	Y31	Y32	Y33	Y34	Y35	Y36		0,5	1	1,5	2	3	5	7	10
X							337	0,40	0,57	0,69	0,80	0,98	1,26	1,50	1,79
X							348	0,50	0,71	0,87	1,00	1,22	1,58	1,87	2,24
X							359	0,63	0,88	1,08	1,25	1,53	1,98	2,34	2,80
X	X						372	0,80	1,13	1,39	1,60	1,96	2,53	2,99	3,58
X	X						383	1,00	1,41	1,73	2,00	2,45	3,16	3,74	4,47
X	X						394	1,25	1,77	2,17	2,50	3,06	3,95	4,68	5,6
X	X						406	1,60	2,26	2,77	3,20	3,92	5,1	6,0	7,2
X	X						418	2,00	2,83	3,46	4,00	4,90	6,3	7,5	8,9
X	X						429	2,50	3,54	4,33	5,0	6,1	7,9	9,4	11,2
X	X						441	3,15	4,45	5,5	6,3	7,7	10,0	11,8	14,1
X	X						453	4,00	5,7	6,9	8,0	9,8	12,6	15,0	17,9
	X						464	5,0	7,1	8,7	10,0	12,2	15,8	18,7	22,4
	X						475	6,3	8,8	10,8	12,5	15,3	19,8	23,4	28,0
	X						488	8,0	11,3	13,9	16,0	19,6	25,3	29,9	35,8
	X	X					499	10,0	14,1	17,3	20,0	24,5	31,6	37,4	44,7
	X	X					510	12,5	17,7	21,7	25,0	30,6	39,5	46,8	56
		X					522	16,0	22,6	27,7	32,0	39,2	51	60	72
		X					534	20,0	28,3	34,6	40,0	49,0	63	75	89
			X				545	25,0	35,4	43,3	50	61	79	94	112
			X				557	31,5	44,5	55	63	77	100	118	141
				X			569	40,0	57	69	80	98	126	150	179
				X			580	50	71	87	100	122	158	187	224
					X		591	63	88	108	125	153	198	234	280
						X	604	80	113	139	160	196	253	299	359
						X	615	100	141	173	200	245	326	374	447



Ugelli assiali a getto piatto - Serie OV Axial-feed vee-jet nozzles - OV Series

Per richiedere qualsiasi informazione sui nostri prodotti visita il sito www.cbnsrl.it

For more information about our products please visit website www.cbnsrl.it





Ugelli assiali a getto piatto - Serie OV1
Axial-feed vee-jet nozzles - OV1 Series



Ugelli assiali a getto piatto - Serie OV1

Axial-feed vee-jet nozzles - OV1 Series

Getto ad impatto elevato
High impact jet

OV1

Caratteristiche

- Getto piatto ad estremità rastremate
- Elevata forza di impatto
- Ingombro ridotto
- Privo di ostacoli interni, molto resistente all'occlusione

Features

- Flat jet with tapered ends
- High impact force
- Compact design
- No internal components, obstruction-proof

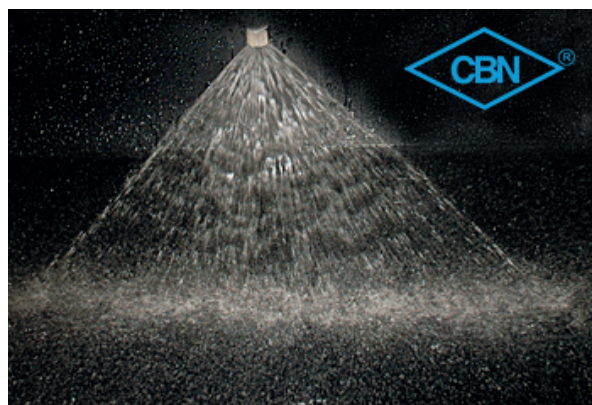

Applicazioni

- Lavaggio e raffreddamento materiali
- Trattamento superfici
- Sistemi antincendio
- Lavatrici e lavastoviglie industriali
- Vasche galvaniche
- Industria siderurgica, tessile e cartaria

Applications

- Materials washing and cooling
- Surface treatments
- Fire-fighting systems
- Industrial washing and dishwashing machines
- chemical-industrial treatments
- Steel, textile and paper factories

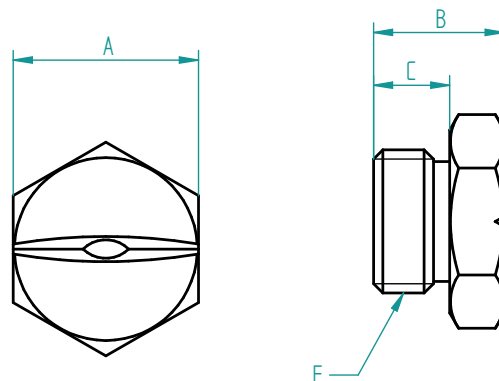

Dimensioni <i>Dimensions</i>	Raccordo - Thread	
	Y02	Y04
F	1/4" BSP M.	1/2" BSP M.
A	17	24
B	12	15
C	7	9

Materiali <i>Materials</i>	Raccordo - Thread	
	Y02	Y04
AISI 316 - 02	x	x
Ottone / Brass - 06	x	x

	Raccordo - Thread		CODICE PORTATA FLOW CODE	Curva di funzionamento - Operating Curve								
	1/4"	1/2"		Portata - Flow rate [l/min] alla pressione - at pressure [bar]								
	Y02	Y04		0,5	0,7	1	1,5	2	3	5	7	10
Angolo / Angle 25°	x		383	1,00	1,18	1,41	1,73	2,00	2,45	3,16	3,74	4,47
	x		394	1,25	1,48	1,77	2,17	2,50	3,06	3,95	4,68	5,6
	x		406	1,60	1,89	2,26	2,77	3,20	3,92	5,06	6,0	7,2
	x		418	2,00	2,37	2,83	3,46	4,00	4,90	6,3	7,5	8,9
	x		429	2,50	2,96	3,54	4,33	5,0	6,1	7,9	9,4	11,2
	x		453	4,00	4,73	5,7	6,9	8,0	9,8	12,6	15,0	17,9
	x		475	6,3	7,4	8,8	10,8	12,5	15,3	19,8	23,4	28,0
	x	x	499	10,0	11,8	14,1	17,3	20,0	24,5	31,6	37,4	44,7
		x	522	16,0	18,9	22,6	27,7	32,0	39,2	51	60	72
	x	545	25,0	29,6	35,4	43,3	50	61	79	94	112	



	Raccordo - Thread		CODICE PORTATA FLOW CODE	Curva di funzionamento - Operating Curve								
	1/4"	1/2"		Portata - Flow rate [l/min] alla pressione - at pressure [bar]								
	Y02	Y04		0,5	0,7	1	1,5	2	3	5	7	10
Angolo / Angle 45°	x		383	1,00	1,18	1,41	1,73	2,00	2,45	3,16	3,74	4,47
	x		406	1,60	1,89	2,26	2,77	3,20	3,92	5,1	6,0	7,2
	x		418	2,00	2,37	2,83	3,46	4,00	4,90	6,3	7,5	8,9
	x		429	2,50	2,96	3,54	4,33	5,0	6,1	7,9	9,4	11,2
	x		441	3,15	3,73	4,45	5,5	6,3	7,7	10,0	11,8	14,1
	x		453	4,00	4,73	5,7	6,9	8,0	9,8	12,6	15,0	17,9
	x		464	5,0	5,9	7,1	8,7	10,0	12,2	15,8	18,7	22,4
	x		475	6,3	7,4	8,8	10,8	12,5	15,3	19,8	23,4	28,0
	x		488	8,0	9,5	11,3	13,9	16,0	19,6	25,3	29,9	35,8
	x	x	499	10,0	11,8	14,1	17,3	20,0	24,5	31,6	37,4	44,7
	x	x	510	12,5	14,8	17,7	21,7	25,0	30,6	39,5	46,8	56
		x	522	16,0	18,9	22,6	27,7	32,0	39,2	51	60	72
		x	534	20,0	23,7	28,3	34,6	40,0	49,0	63	75	89
		x	545	25,0	29,6	35,4	43,3	50	61	79	94	112
	x	557	31,5	37,3	44,5	55	63	77	100	118	141	

	Raccordo - Thread		CODICE PORTATA FLOW CODE	Curva di funzionamento - Operating Curve								
	1/4"	1/2"		Portata - Flow rate [l/min] alla pressione - at pressure [bar]								
	Y02	Y04		0,5	0,7	1	1,5	2	3	5	7	10
Angolo / Angle 60°			372	0,80	0,95	1,13	1,39	1,60	1,96	2,53	2,99	3,58
	x		383	1,00	1,18	1,41	1,73	2,00	2,45	3,16	3,74	4,47
	x		394	1,25	1,48	1,77	2,17	2,50	3,06	3,95	4,68	5,6
	x		406	1,60	1,89	2,26	2,77	3,20	3,92	5,1	6,0	7,2
	x		418	2,00	2,37	2,83	3,46	4,00	4,90	6,3	7,5	8,9
	x		429	2,50	2,96	3,54	4,33	5,0	6,1	7,9	9,4	11,2
	x		441	3,15	3,73	4,45	5,5	6,3	7,7	10,0	11,8	14,1
	x		453	4,00	4,73	5,7	6,9	8,0	9,8	12,6	15,0	17,9
	x		464	5,0	5,9	7,1	8,7	10,0	12,2	15,8	18,7	22,4
	x		475	6,3	7,4	8,8	10,8	12,5	15,3	19,8	23,4	28,0
	x		488	8,0	9,5	11,3	13,9	16,0	19,6	25,3	29,9	35,8
	x	x	499	10,0	11,8	14,1	17,3	20,0	24,5	31,6	37,4	44,7
	x	x	510	12,5	14,8	17,7	21,7	25,0	30,6	39,5	46,8	56
		x	522	16,0	18,9	22,6	27,7	32,0	39,2	51	60	72
		x	534	20,0	23,7	28,3	34,6	40,0	49,0	63	75	89
		x	545	25,0	29,6	35,4	43,3	50	61	79	94	112
		x	557	31,5	37,3	44,5	55	63	77	100	118	141

	Raccordo - Thread		CODICE PORTATA FLOW CODE	Curva di funzionamento - Operating Curve								
	1/4"	1/2"		Portata - Flow rate [l/min] alla pressione - at pressure [bar]								
	Y02	Y04		0,5	0,7	1	1,5	2	3	5	7	10
Angolo / Angle 90°	x		372	0,80	0,95	1,13	1,39	1,60	1,96	2,53	2,99	3,58
	x		383	1,00	1,18	1,41	1,73	2,00	2,45	3,16	3,74	4,47
	x		394	1,25	1,48	1,77	2,17	2,50	3,06	3,95	4,68	5,6
	x		406	1,60	1,89	2,26	2,77	3,20	3,92	5,1	6,0	7,2
	x		418	2,00	2,37	2,83	3,46	4,00	4,90	6,3	7,5	8,9
	x		429	2,50	2,96	3,54	4,33	5,0	6,1	7,9	9,4	11,2
	x		441	3,15	3,73	4,45	5,5	6,3	7,7	10,0	11,8	14,1
	x		453	4,00	4,73	5,7	6,9	8,0	9,8	12,6	15,0	17,9
	x		464	5,0	5,9	7,1	8,7	10,0	12,2	15,8	18,7	22,4
	x		475	6,3	7,4	8,8	10,8	12,5	15,3	19,8	23,4	28,0
	x		488	8,0	9,5	11,3	13,9	16,0	19,6	25,3	29,9	35,8
	x	x	499	10,0	11,8	14,1	17,3	20,0	24,5	31,6	37,4	44,7
	x	x	510	12,5	14,8	17,7	21,7	25,0	30,6	39,5	46,8	56
		x	522	16,0	18,9	22,6	27,7	32,0	39,2	51	60	72
		x	534	20,0	23,7	28,3	34,6	40,0	49,0	63	75	89
	x	545	25,0	29,6	35,4	43,3	50	61	79	94	112	
	x	557	31,5	37,3	44,5	55	63	77	100	118	141	

	Raccordo - Thread		CODICE PORTATA FLOW CODE	Curva di funzionamento - Operating Curve								
	1/4"	1/2"		Portata - Flow rate [l/min] alla pressione - at pressure [bar]								
	Y02	Y04		0,5	0,7	1	1,5	2	3	5	7	10
Angolo / Angle 120°	x		372	0,80	0,95	1,13	1,39	1,60	1,96	2,53	2,99	3,58
	x		383	1,00	1,18	1,41	1,73	2,00	2,45	3,16	3,74	4,47
	x		394	1,25	1,48	1,77	2,17	2,50	3,06	3,95	4,68	5,6
	x		406	1,60	1,89	2,26	2,77	3,20	3,92	5,1	6,0	7,2
	x		418	2,00	2,37	2,83	3,46	4,00	4,90	6,3	7,5	8,9
	x		429	2,50	2,96	3,54	4,33	5,0	6,1	7,9	9,4	11,2
	x		441	3,15	3,73	4,45	5,5	6,3	7,7	10,0	11,8	14,1
	x		453	4,00	4,73	5,7	6,9	8,0	9,8	12,6	15,0	17,9
	x		464	5,0	5,9	7,1	8,7	10,0	12,2	15,8	18,7	22,4
	x		475	6,3	7,4	8,8	10,8	12,5	15,3	19,8	23,4	28,0
	x		488	8,0	9,5	11,3	13,9	16,0	19,6	25,3	29,9	35,8
	x	x	499	10,0	11,8	14,1	17,3	20,0	24,5	31,6	37,4	44,7
	x	x	510	12,5	14,8	17,7	21,7	25,0	30,6	39,5	46,8	56
		x	522	16,0	18,9	22,6	27,7	32,0	39,2	51	60	72
		x	534	20,0	23,7	28,3	34,6	40,0	49,0	63	75	89

Per richiedere qualsiasi
informazione sui nostri prodotti
visita il sito www.cbnsrl.it

For more information about our
products please visit website
www.cbnsrl.it

