

Serie OL75

Ugelli a getto piatto deflesso



CARATTERISTICHE

- Getto deflesso a 75°
- Copertura molto ampia



APPLICAZIONI

- Lavaggio filtri
- Linee di raffreddamento

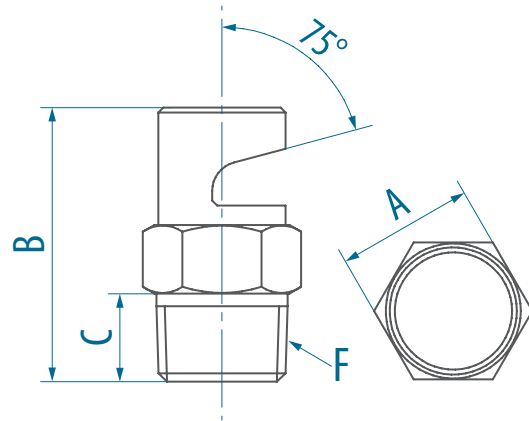

Codice Raccordo	
Dim.	Y32
F	1/4"
A	14
B	28
C	9

DATI OPERATIVI

ANGOLO	Materiale			Rac.	COD. PORTATA	Curva di funzionamento							
	04	06	08	Y32		Portata scaricata [l/min] alla pressione [bar(g)]							
	AISI 303	Ottone	PVC	1/4" BSPT		0,5	0,7	1	1,5	2	3	5	7
140°	x	x	x	x	383	1,00	1,18	1,41	1,73	2,00	2,45	3,16	3,74
	x	x	x	x	394	1,25	1,48	1,77	2,17	2,50	3,06	3,95	4,68
	x	x	x	x	406	1,60	1,89	2,26	2,77	3,20	3,92	5,06	5,99
	x	x	x	x	418	2,00	2,37	2,83	3,46	4,00	4,90	6,32	7,48
	x	x	x	x	429	2,50	2,96	3,54	4,33	5,00	6,12	7,91	9,35
	x	x	x	x	441	3,15	3,73	4,45	5,46	6,30	7,72	10,0	11,8
	x	x	x	x	453	4,00	4,73	5,66	6,93	8,00	9,80	12,6	15,0
	x	x	x	x	464	5,00	5,92	7,07	8,66	10,0	12,2	15,8	18,7
	x	x	x	x	475	6,25	7,40	8,8	10,8	12,5	15,3	19,8	23,4
	x	x	x	x	488	8,00	9,47	11,3	13,9	16,0	19,6	25,3	29,9