

Serie OLP

Ugelli a getto piatto deflesso



CARATTERISTICHE

- Getto deflesso a 10-20°
- Forza di impatto molto elevata



APPLICAZIONI

- Lavaggi speciali
- Decappaggio superfici

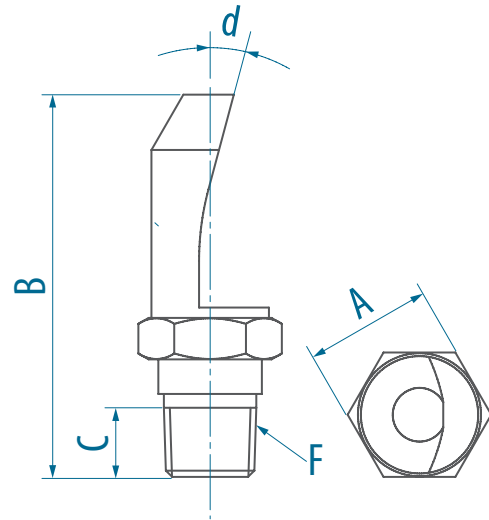

Dim.	Codice Raccordo
	Y32
F	1/4"
A	17
B	55
C	10
d	10-20°

DATI OPERATIVI

ANGOLO	Materiale			Rac.	COD. PORTATA	Curva di funzionamento							
	04	06	08	Y32		Portata scaricata [l/min] alla pressione [bar(g)]							
	AISI 303	Ottone	PVC	1/4" BSPT		0,5	0,7	1	1,5	2	3	5	7
45°	x	x	x	x	406	1,60	1,89	2,26	2,77	3,20	3,92	5,06	5,99
	x	x	x	x	418	2,00	2,37	2,83	3,46	4,00	4,90	6,32	7,48
	x	x	x	x	429	2,50	2,96	3,54	4,33	5,00	6,12	7,91	9,35
	x	x	x	x	441	3,15	3,73	4,45	5,46	6,30	7,72	10,0	11,8
	x	x	x	x	453	4,00	4,73	5,66	6,93	8,00	9,80	12,6	15,0