



CARATTERISTICHE

- Interamente in AISI 316
- Dimensioni contenute



APPLICAZIONI

- Lavaggio interno di forni

Serie TR

Ugelli auto-rotanti

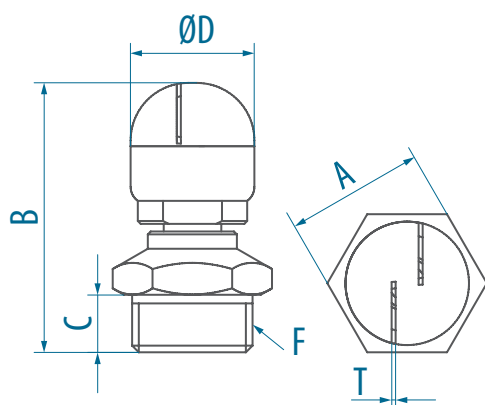

Dim.	Codice Raccordo		
	Y02	Y03	Y04
F	1/4"	3/8"	1/2"
A	17	19	24
B	33	39	47
C	8,5	8,5	10
D	13,5	16,5	21,5

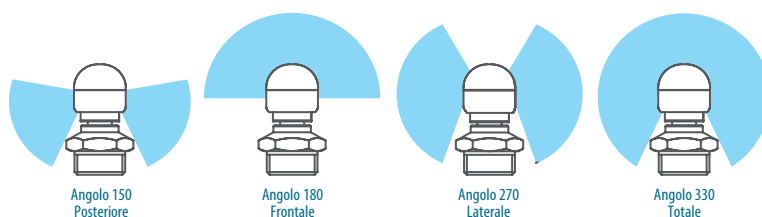

DATI OPERATIVI

Copertura				Mat.	Raccordo			COD. PORTATA	Curva di funzionamento							
150	180	270	330		02	Y02	Y03		Y04	Portata scaricata [l/min] alla pressione [bar(g)]						
Posteriore	Anteriore	Laterale	Totale	AISI 316	1/4" BSP M.	3/8" BSP M.	1/2" BSP M.	0,5	0,7	1	1,5	2	2,5	3	4	
x	x	x	x	x	x	-	-	429	2,50	2,96	3,54	4,33	5,0	5,6	6,1	7,1
x	x	x	x	x	x	x	-	441	3,15	3,73	4,45	5,5	6,3	7,0	7,7	8,9
x	x	x	x	x	x	-	x	453	4,00	4,73	5,7	6,9	8,0	8,9	9,8	11,3
x	x	x	x	x	x	-	x	464	5,0	5,9	7,1	8,7	10,0	11,2	12,2	14,1
x	x	x	x	x	x	-	x	475	6,3	7,4	8,8	10,8	12,5	14,0	15,3	17,7
x	x	x	x	x	x	-	-	488	8,0	9,5	11,3	13,9	16,0	17,9	19,6	22,6
x	x	x	x	x	x	-	-	499	10,0	11,8	14,1	17,3	20,0	22,4	24,5	28,3
x	x	x	x	x	x	-	-	510	12,5	14,8	17,7	21,7	25,0	28,0	30,6	35,4