

## CLW Series

Tangential-flow hollow cone nozzles



### FEATURES

- AISI 316 stainless steel insert
- Max Temperature 100°C



### APPLICATIONS

- Foam suppression
- Air treatment

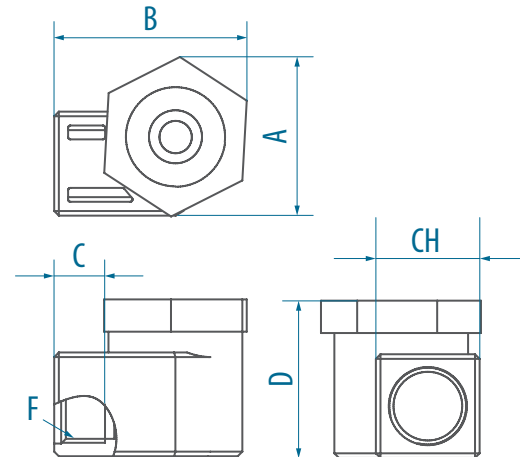

Dim.	Thread Code
	X03
F	3/8"
CH	23
A	35
B	42
C	8
D	34

### OPERATIVE DATA

ANGLE	Mat.	Thr.	FLOW CODE	Operating curve									
	33	X03		Flow-rate discharged [l/min] at pressure [bar(g)]									
	PP/GF	3/8" BSP F.		0,5	0,7	1	1,5	2	2,5	3	4	5	
90°	x	x	424	2,25	2,66	3,18	3,90	4,50	5,03	5,51	6,36	7,12	
	x	x	437	2,95	3,49	4,17	5,11	5,90	6,60	7,23	8,34	9,33	
	x	x	440	3,10	3,67	4,38	5,37	6,20	6,93	7,59	8,77	9,80	
	x	x	453	4,00	4,73	5,66	6,93	8,00	8,94	9,80	11,3	12,6	
	x	x	469	5,50	6,51	7,78	9,53	11,0	12,3	13,5	15,6	17,4	