

## F7 Series

Tangential-flow hollow cone nozzles



### FEATURES

- Made from die casting



### APPLICATIONS

- Bituminous emulsions
- Fire-fighting systems

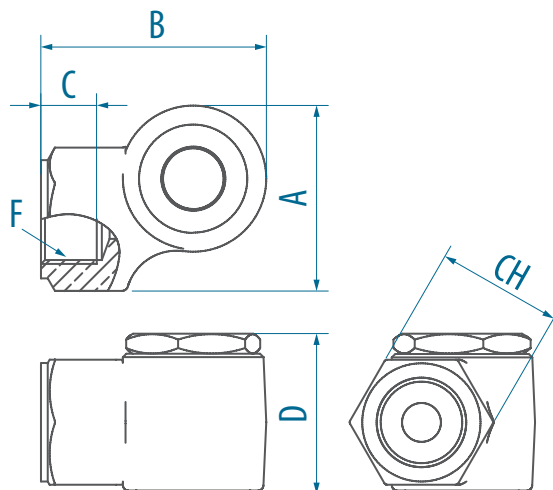
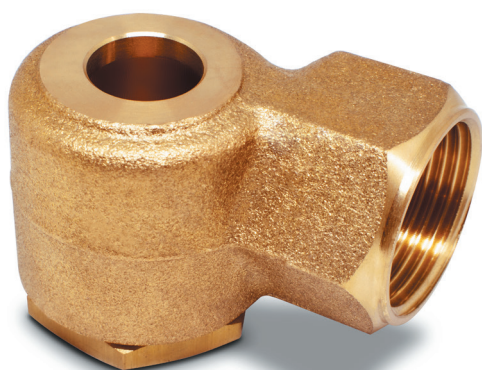

Dim.	Thread Code	
	X05	X06
F	3/4"	1"
A	55	55
B	67	67
C	16	16
D	48	48
CH	37	37

### OPERATIVE DATA

ANGLE	Mat.	Thread		FLOW CODE	Operating curve									
	06	X05	X06		Flow-rate discharged [l/min] at pressure [bar(g)]									
	Brass	3/4" BSP F	1" BSP F		0,5	0,7	1	1,5	2	3	5	7	10	
90°	x	x	x	499	10,0	11,8	14,1	17,3	20,0	24,5	31,6	37,4	44,7	
	x	x	x	522	16,0	18,9	22,6	27,7	32,0	39,2	50,6	59,9	71,6	
	x	x	x	545	25,0	29,6	25,4	43,3	50,0	61,2	79,1	93,5	112	
	x	x	x	569	40,0	47,3	56,6	69,3	80,0	98,0	127	150	179	
120°	x	x	x	499	10,0	11,8	14,1	17,3	20,0	24,5	31,6	37,4	44,7	
	x	x	x	522	16,0	18,9	22,6	27,7	32,0	39,2	50,6	59,9	71,6	
	x	x	x	545	25,0	29,6	25,4	43,3	50,0	61,2	79,1	93,5	112	
	x	x	x	569	40,0	47,3	56,6	69,3	80,0	98,0	127	150	179	